

# AECB CarbonLite Programme

Delivering buildings with excellent energy and CO<sub>2</sub> performance

## AECB CarbonLite Design & Construction Guidance: Part 1

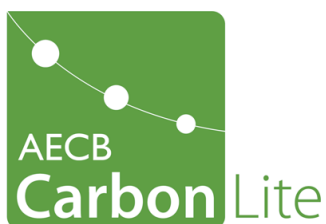
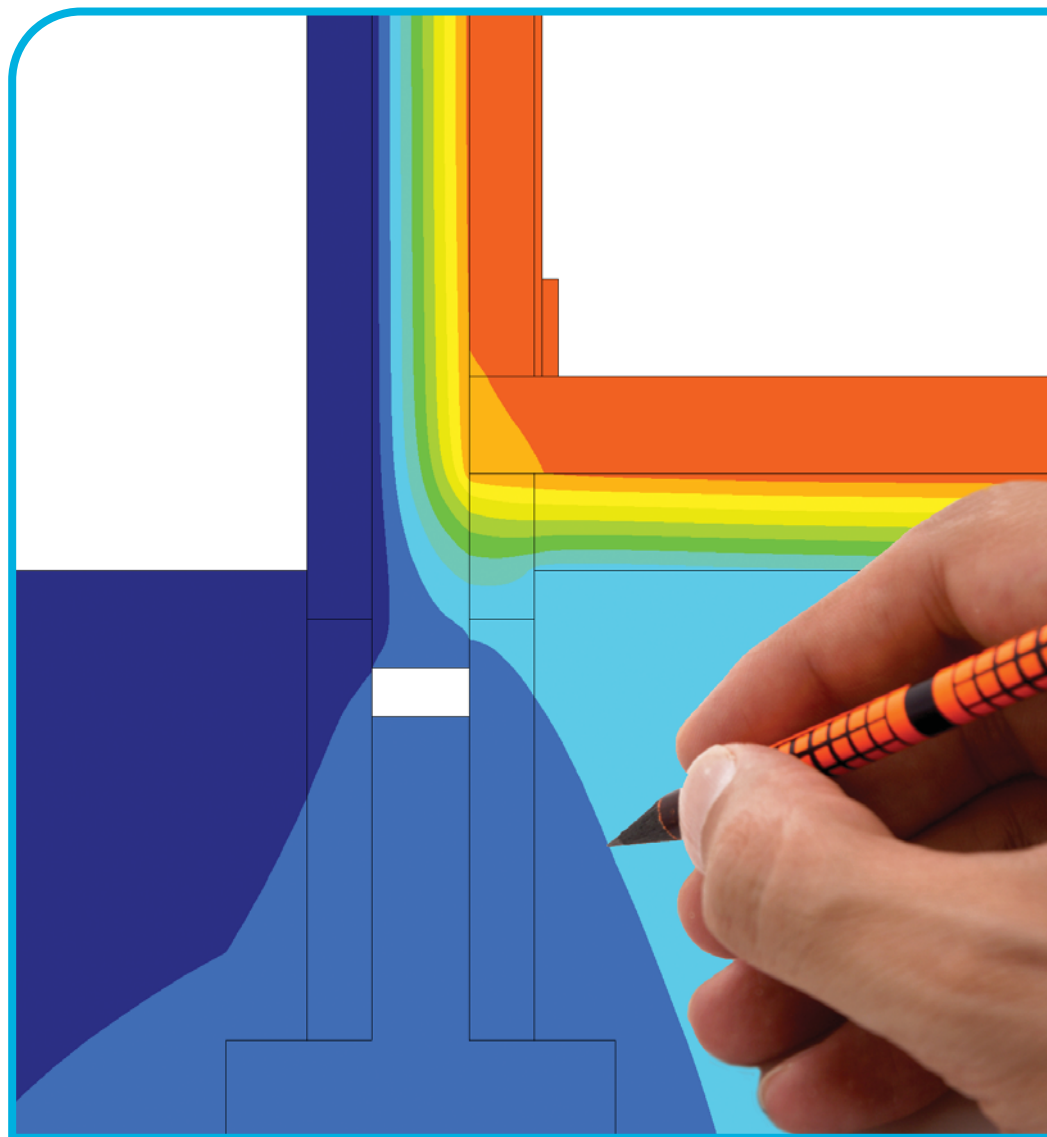

CARBON LITERATE DESIGN AND CONSTRUCTION

# Contents

## Glossary of main terms

### U-value

thermal transmittance - units  $W/m^2K$

### R-value

thermal resistance - units  $m^2W/K$

### Air permeability

units  $m^3/m^2hr$  at 50 Pascals  
or  $m/hr$  @ 50 Pa

### (k or lambda) K or $\lambda$ -value

thermal conductivity of a material -  
units  $W/mK$

### (psi) $\psi$ -value

linear thermal bridge heat loss  
coefficient - units  $W/mK$

### (y) y-value

Linear thermal transmittance -  
units  $W/m^2k$

### R<sub>so</sub>

Resistance of outside surface

### R<sub>si</sub>

Resistance of internal surface

<b>Section 1</b>	<b>Introduction</b> .....	<b>3</b>
<b>Section 2</b>	<b>Masonry</b> .....	<b>6</b>
2.1	Fully filled cavity - basic principles .....	6
2.1.1	The basic construction - plane elements .....	7
2.1.2	Wall to floor junction .....	11
2.1.3	Window to wall junction .....	13
2.1.4	Roof to wall junction .....	16
<b>Section 3</b>	<b>Timber frame</b> .....	<b>17</b>
3.1	Platform frame (room in roof format) - basic principles .....	20
3.1.1	The basic construction - plane elements .....	21
3.1.2	Roof to wall junction .....	25
3.1.3	Wall to suspended ground floor junction .....	27
3.1.4	Timber-frame wall and intermediate timber floor junction, parallel to joists .....	29

AECB  
PO Box 32, Llandysul  
Carmarthenshire, SA44 5ZA  
T: 0845 456 9773  
[www.aecb.net](http://www.aecb.net)

The CarbonLite Programme is funded by:



# Introduction

## SECTION 1

To support 'early adopters' pioneering Passivhaus and the AECB Building Standard (previously called AECB Silver), the AECB produced this design guidance document (in two parts) in 2007: over the last 13 years more and more practitioners have changed the way they design and build - achieving better performing and more comfortable buildings. The details illustrated have been successfully built, refined and varied to suit individual project challenges. This document remains a hugely useful guidance and learning resource for next stage adopters, the 'early majority'. The guidance concentrates on two of the areas where 'mainstream' UK practice most adversely affects building energy performance - thermal bridging and airtightness.

It is written in the context of constructional examples illustrating certain U values that might be commonly required for achieving the AECB Building Standard or the Passivhaus Standard, it can also more generally usefully inform design and construction aiming to reduce the performance gap and improve building occupants satisfaction levels. Please note that the AECB and Passivhaus Standards are performance based standards - so U values required will vary from project to project. The key design and construction principles illustrated in these guides are intended to be useful to skilled persons acting in a professional and commercial capacity who are attempting to design more thermally-efficient building envelopes.

Many of the examples used here have been used on "live" projects by various AECB members.

Please use these constructional examples to inform the detailed design of your own project's building fabric. Applying the principles of reduced thermal bridging and increased airtightness to all fabric elements - walls, floors, roof, etc - and key junctions between elements will significantly reduce your building's overall energy use and CO<sub>2</sub> emissions.

It is intended that these details be treated as constructional examples only, to illustrate the application of good thermal design principles. Do not treat them as "approved" or "accredited" details as they have not yet been through the necessary peer review process to gain this additional authority.

It is hoped that skilled persons acting in a professional or commercial capacity who are attempting to design more thermally-efficient building envelopes can utilise the constructional examples in their own work but the information contained in this document has not been prepared to meet any individual's specific requirements or any particular given circumstances and you must exercise your own professional judgment and expertise to assess the suitability of the constructional examples for use or adaptation in your own designs and under your own particular circumstances.

Whilst reasonable care has been taken when compiling the information in this document and AECB believe it to be accurate it is provided without responsibility and AECB shall not be liable for any loss, damage or expenses (including loss of profits, loss of contracts, business or goodwill howsoever arising).

These constructional examples are used to show how key design principles can be applied to common details. The U-value and  $\psi$  value of each constructional example is given and there is a commentary on how thermal bridging is reduced and airtightness is improved.

The  $\psi$  values quoted here are based on both on internal dimensions ( $\psi_{int}$  - UK method) and also external dimensions ( $\psi_{ext}$  - method used by Passivhaus Institut). Either method, if applied carefully, will give the correct result.

### 2.1: Fully-filled cavity - basic principles

The basic principles for achieving well-insulated and airtight masonry construction are discussed. The requirements for reducing thermal bridges and reducing the risk of interstitial condensation are covered.

The construction details illustrated in this document show how building envelopes can be designed to:

- Be highly-insulated and airtight;
- Have reduced thermal bridging; and
- Minimise the risk of interstitial condensation.

This can be achieved by following three simple rules.

1. Ensure that the construction has a designated air barrier; i.e., a layer in the structure which blocks air movement, and if necessary a vapour barrier; i.e., one which controls vapour diffusion. In masonry wall construction, the air barrier may be wet plaster or parging; in a concrete wall, the material itself can be a good air barrier; and in a timber frame structure it may be a polyethylene membrane - similarly in the timber roof of a masonry or concrete building.
2. Make the insulation continuous so that the insulation in one element connects seamlessly to the insulation in the next element. This reduces or almost eliminates the linear non-repeating thermal bridges.
3. Make sure that the insulation is contained within airtight layers, ideally to both sides. This ensures that cold outside air does not find its way to the warm side of the insulation.

## 2.1.1: The basic construction – wall

### SECTION 2

FIGURE 1

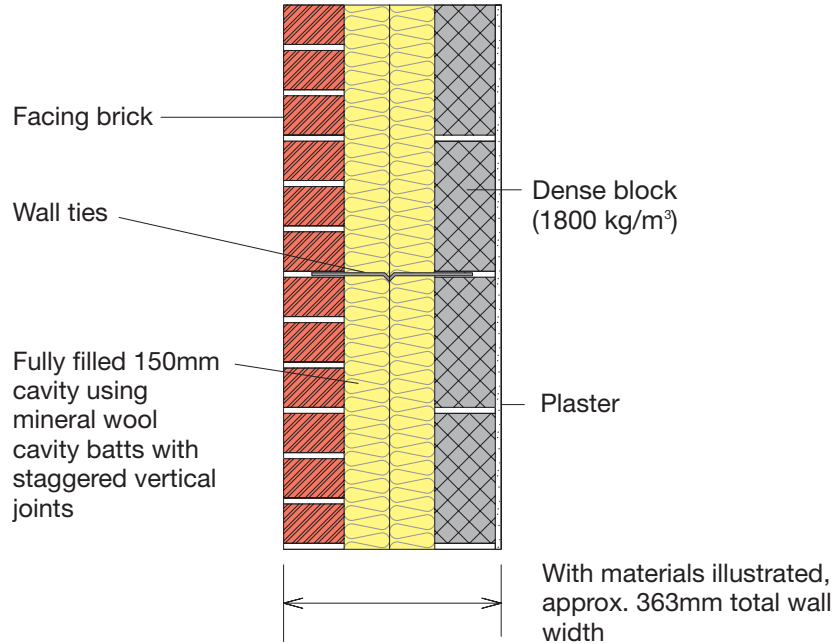

#### U-values (UK approach)

With stainless steel wall ties,

**U = 0.25 W/m<sup>2</sup>K**

With plastic wall ties,

**U = 0.23 W/m<sup>2</sup>K**

See page 15 for assumptions

#### ψ values for linear thermal bridges at wall corners

	ψ <sub>int</sub> W/mK	ψ <sub>ext</sub> W/mK
As shown		
External corner	0.06	0.00
Internal corner	-0.06	0.00
Party wall	0.08	0.00
Compare UK Accredited Constructions	0.16	

#### Notes

1. Fully filled cavities can be used in all exposure categories, but may have some insurance restrictions in 'very severe' zones (these are not technical or regulatory restrictions). Check the site driving rain index. In 'severe' or 'very severe' zones it may be appropriate to consider an alternative finish to fair-faced masonry; e.g., render, tile- or slate-hanging.
2. Normally the inner leaf is treated as the load-bearing leaf with the outer leaf taking wind loads via the wall ties.



FIGURE 2

Partial fill cavity construction  
This is a good example of poor workmanship exacerbating the problems of an inherently poor and hard to build detail.

PHOTO: TONY MOULD

The diagram above shows a cavity masonry external wall with 150 mm of full-fill mineral fibre insulation; e.g. Rockwool or Dritherm cavity wall batts. This is the basic wall construction assumed in this document. Dense concrete blockwork has been illustrated in Figure 1 as one example of how to maximise thermal capacity in a building structure for the benefit of utilising passive solar gains and reducing overheating risks.

The U-value illustrated for the wall with 150mm insulation and steel ties is 0.247 W/m<sup>2</sup>K, which is very close to the upper limit permitted by the Silver Standard, namely a maximum U-value plus y-value of 0.25 W/m<sup>2</sup>K if following the UK approach and a maximum U-value of 0.25 W/m<sup>2</sup>K if following the PHI approach. The exact U-value needed in some cases may be lower, in order to meet the Standard's limit on the Heat Loss Parameter (HLP).

### Limiting Thermal Bridges

This relatively simple wall construction - four layers of relatively basic materials - sidesteps some of the pitfalls associated with other masonry wall constructions. These pitfalls include:

1. Potential difficulties associated with successfully plastering ultra-lightweight concrete blocks if they are used in the inner leaf; and
2. The higher risks of poor workmanship with partial fill foam slabs and the consequent air movement in and around the insulation, reducing its performance; see figure 2.

Mineral wool can be built in as semi-rigid batts or filled post-construction using an appropriate specialist product. Issues to consider with this wall construction include:

1. Its resistance to driving rain;
2. The risk of poorly-filled perpendes - see below;
3. Thermal bridging by the stainless steel wall ties, given that cavities wider than 100 mm may use more robust ties; and
4. The need for a thermal break where the external wall meets the foundation.

Plastic wall ties eliminate problem 3 and can reduce the U-value by 6-10%.

### Airtightness

The airtightness of the wall is provided by the internal plaster finish. Care must be taken to prevent the wind blowing through the insulation via poorly-filled perpendes. On exposed sites, render appears to be a more suitable finish than fair-faced masonry. It greatly reduces the risk of air movement through the air-permeable insulation and resulting elevated heat loss.

The internal plaster must be continuous behind stairs, baths, skirtings, electrical boxes, above suspended ceilings and in all other areas where plastering is not normally carried out. An alternative to plastering "hidden" areas is a brush-applied parging coat, such as that used for sound insulation.

## 2.1.1: The basic construction – floor

### SECTION 2

FIGURE 3

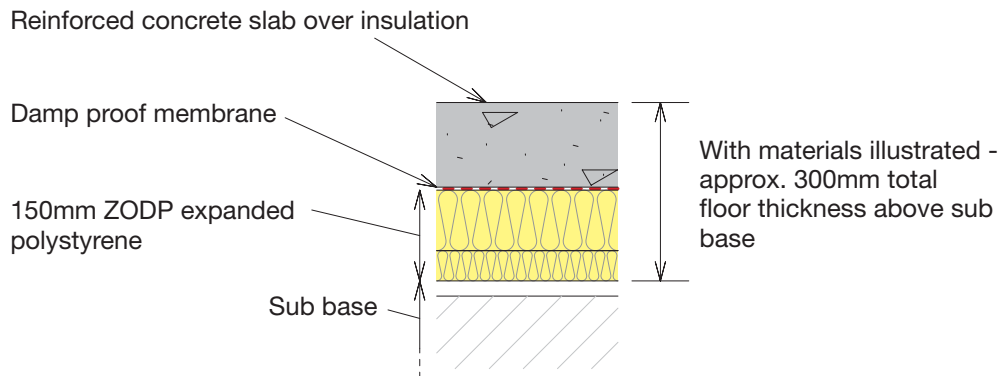

#### U-values (UK approach)

##### Basic floor construction

Assuming perimeter/areas ratio = 0.4 and soil  $k = 1.5 \text{ W/mK}$

**$U = 0.17 \text{ W/m}^2\text{K}$**

#### Notes

- 1 Take care to use the correct grade of expanded polystyrene for your situation. Several different densities are available. The permitted loading rises with increased density.
2. Where issues arise concerning ground moisture potentially entering the body of the floor insulation (and affecting its thermal performance), the DPM may be positioned below the insulation, with a slip layer incorporated between the insulation and the floor slab.
3. The insulation thickness needed depends on the size of slab and ground conditions.

## 2.1.1: The basic construction – roof

### SECTION 2

FIGURE 4

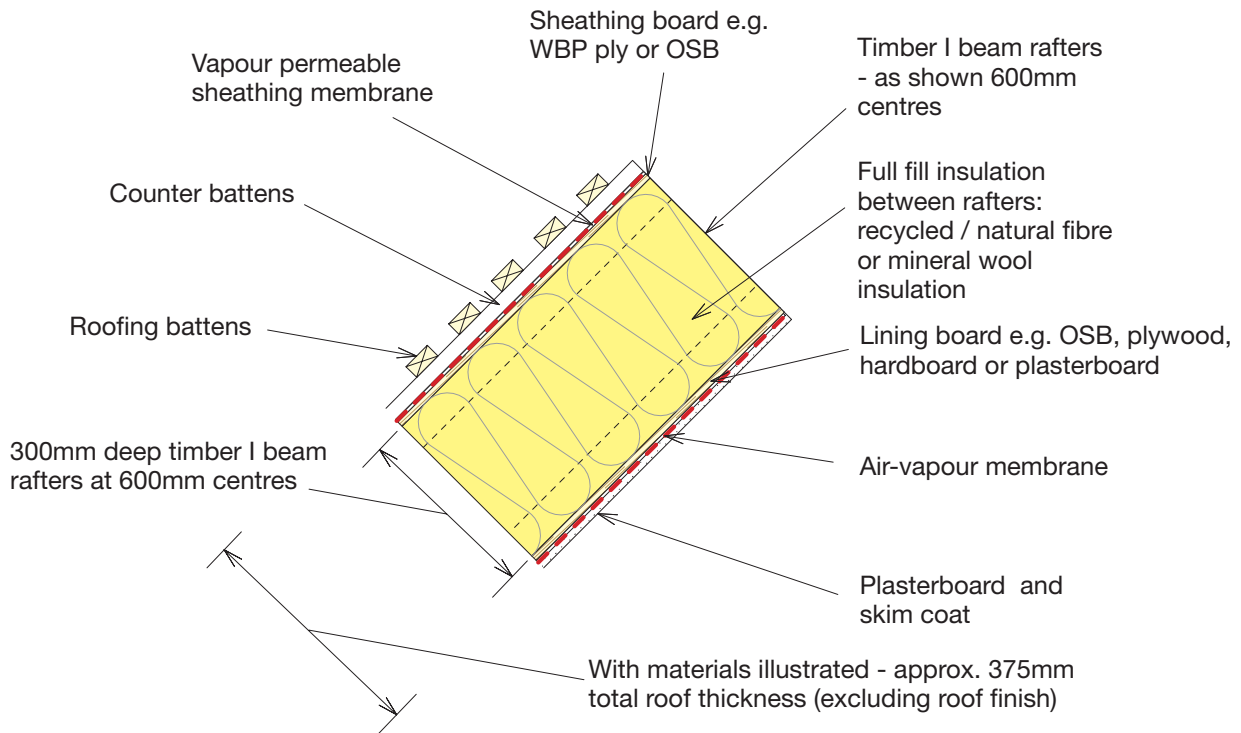

#### U-values (UK approach)

##### Basic roof construction

$U = 0.14 \text{ W/m}^2\text{K}$

#### Notes

1. In the roof construction illustrated, all electrical wiring and other services must be located inside the air-vapour membrane. In illustrating this detail, it has been assumed that it is intended to fit relatively little electrical wiring in the roof of the building. If extensive wiring or deep light fittings are planned; e.g., recessed CFL downlighters, the designer needs to provide a full service cavity (see timber-frame wall detail for guidance on pp 18-19).
2. If any soil vent pipes (SVP), metal flues or chimneys penetrate the roof, they must be sealed tightly to the roof air-vapour membrane. It is normally recommended that air admittance valves be provided as an alternative to full SVPs, nevertheless SVPs are sometimes needed to meet Building Regulations.





### **Reduced Thermal Bridging**

The primary method of limiting thermal bridges is by using ultra-lightweight loadbearing concrete blocks (typically  $\lambda = 0.11$  W/mK above ground and 0.18 W/mK below DPM) combined with the extension of the cavity wall insulation down past the base of the floor insulation. The cavity wall insulation and ultra-lightweight loadbearing blocks should extend at least 150 mm below the bottom of the floor insulation.

Check the load-bearing ability of the proposed ultra-lightweight blocks on a case-by-case basis. As their  $\lambda$ -value declines, so usually does their compressive strength.

### **Airtightness**

The wall air barrier, i.e., the plaster layer, has to join the concrete floor slab which, in this detail, is designated as the floor air barrier. It is recommended to plaster all the way down to the floor slab rather than stop the plaster above the skirting and then attempt to make the skirting part of the air barrier. An alternative could be to use a mastic seal behind the whole of the skirting, bridging between the bottom of the plaster and the top of the concrete, and treat this sealant as part of the air barrier.

Pipes and wires from below need to be run in ducts and the junction with the slab sealed with non-hardening compounds in order to ensure airtightness.

## 2.1.3: Window to wall junction

### SECTION 2

FIGURE 6

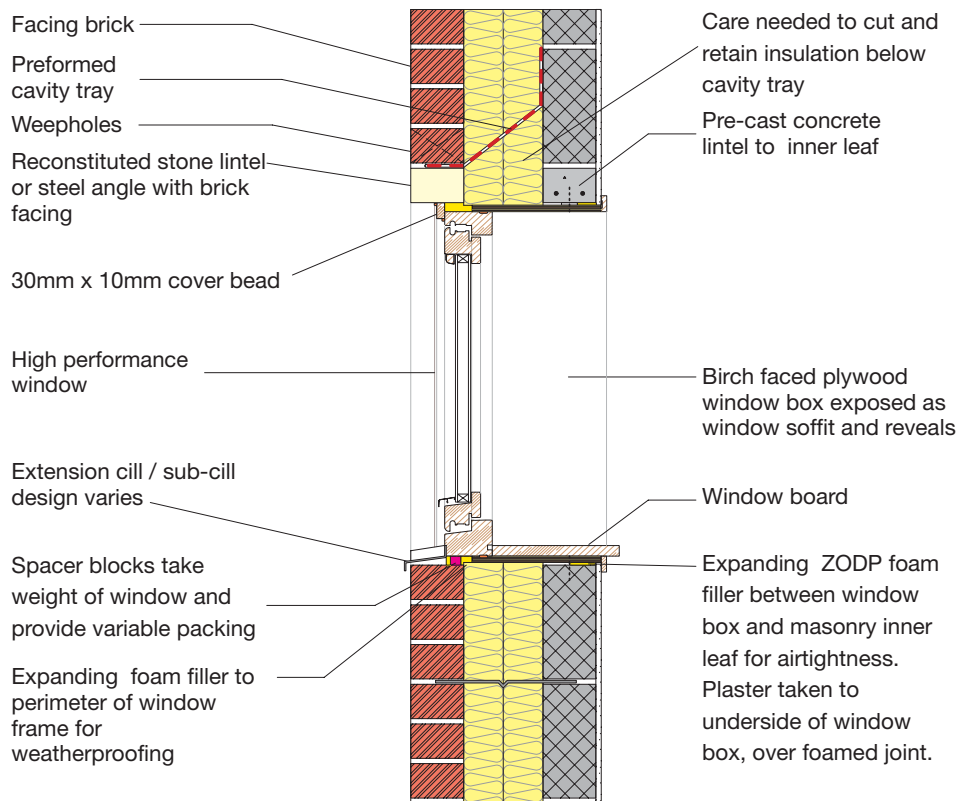

#### ψ values for linear thermal bridges

	ψ <sub>int</sub> W/mK	ψ <sub>ext</sub> W/mK
<b>As shown</b>		
<b>Head</b>	<b>0.06</b>	<b>0.00</b>
<i>Compare UK Accredited Constructions</i>	<i>0.30-0.50</i>	
<b>Sill</b>	<b>0.03</b>	<b>0.03</b>
<i>Compare UK Accredited Constructions</i>	<i>0.04</i>	
<b>Jamb</b>	<b>0.03</b>	<b>0.03</b>
<i>Compare UK Accredited Constructions</i>	<i>0.05</i>	

#### Notes

- 1 The plywood box is designed to be attached and sealed to the window frame before mounting. However, on some projects the box has been built in during blocklaying and used to form the opening.
- 2 Wooden windows must not touch the damp outer leaf at any point. Rather, they are contained within the box, whose weight is supported on the outer leaf via plastic packers.
- 3 On exposed sites, the window can be installed behind the outer leaf, but support brackets are then needed to transmit part of the window's weight to the outer leaf. These brackets must be selected with care so as not to cause excessive thermal bridging.
- 4 Generally an aluminium or stainless steel outer sill is used. The ends need to be either built into the brick outer leaf or to be turned up and overlap behind the render.

#### Isotherms

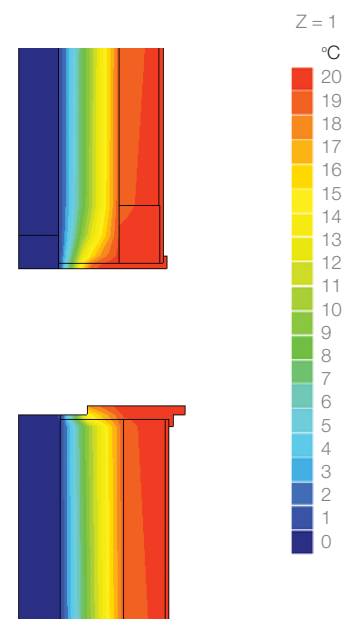

### Reduced Thermal Bridging

The use of one-piece steel lintels creates one of the worst thermal bridges found in modern cavity-walled buildings. The use of masonry returns at the window jambs also offsets much of the benefit of using thicker cavity insulation or higher performance windows. It is also essential that the window glazing unit is mounted within the plane of the wall insulation - see below.

The three main methods of limiting thermal bridges are:

1. Use separate lintels in each leaf - usually concrete or reconstructed stone, but possibly a steel angle where one has to support a fair-faced brick outer leaf;
2. Avoid masonry returns to the jambs;
3. Locate windows within the plane of the thermal insulation.

This gives typical isotherms as shown in figure 6.

### Airtightness

The plywood box needs to be sealed to the masonry wall on the inside to provide the primary air seal. This can be done by foaming with ZODP expanding foam between the box and the blockwork. The box can be used as a plaster stop.

Bear in mind that, if the window is moved too far into the outer leaf, the  $\psi$  values rise steeply. Always aim for the outer face of the glazing to be no further out in the wall than the plane of the thermal insulation.

FIGURE 8

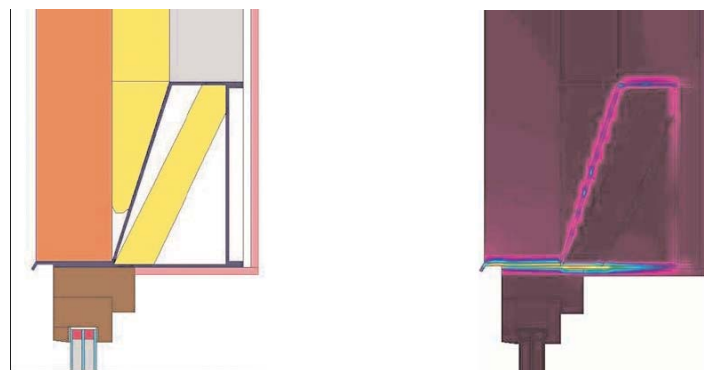

One example of a one piece 'insulated' steel lintel (left) and (right) heat flow through the lintel from the warm side to the cold side.

## 2.1.4: Roof to wall junction

### SECTION 2

FIGURE 9

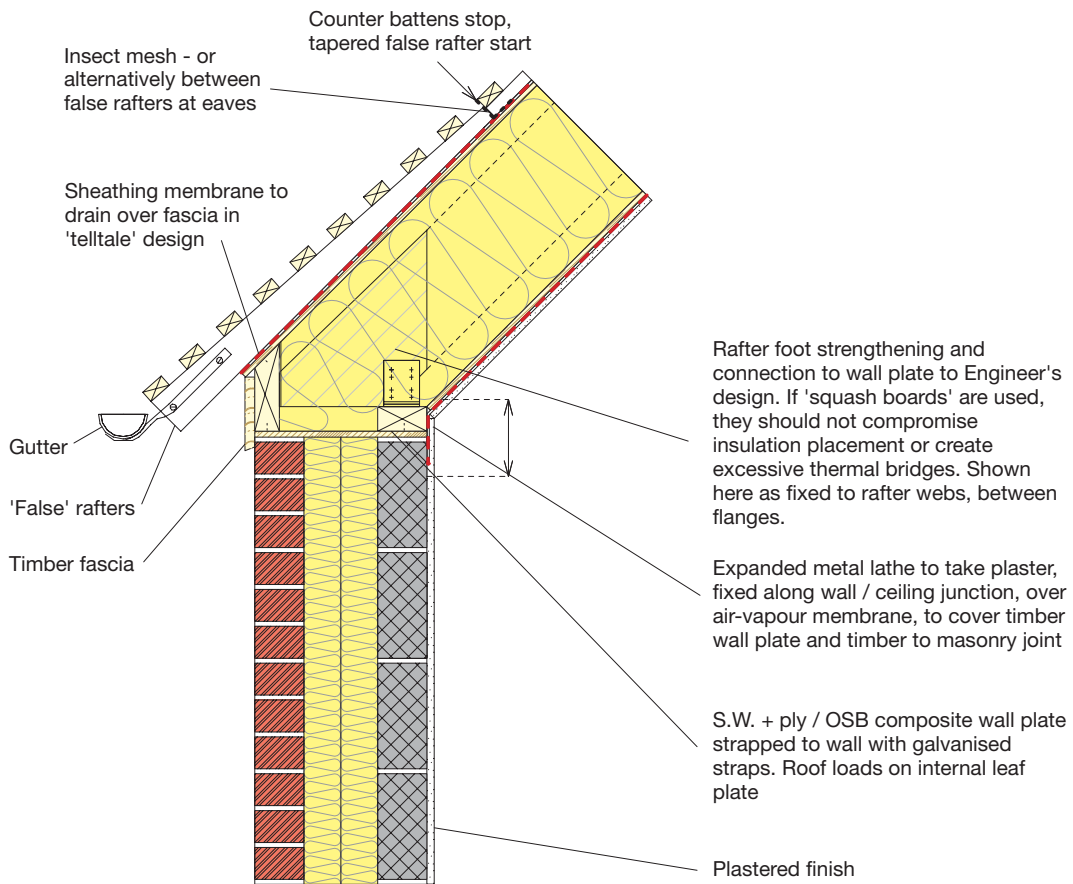

Rafter foot strengthening and connection to wall plate to Engineer's design. If 'squash boards' are used, they should not compromise insulation placement or create excessive thermal bridges. Shown here as fixed to rafter webs, between flanges.

Expanded metal lathe to take plaster, fixed along wall / ceiling junction, over air-vapour membrane, to cover timber wall plate and timber to masonry joint

S.W. + ply / OSB composite wall plate strapped to wall with galvanised straps. Roof loads on internal leaf plate

Plastered finish

#### $\psi$ values for linear thermal bridges

	$\psi_{int}$ W/mK	$\psi_{ext}$ W/mK
<b>As shown</b>		
Eaves	0.03	-0.08
<i>Compare UK Accredited Constructions</i>	0.04	
<b>Verge (For verge, assuming continuous insulation between wall and roof)</b>	0.03	-0.08
<b>Variations</b>		
Without cavity closer	0.00	-0.11

#### Notes

- 1 It is not necessary to install a cavity stop as long as the insulation is continuous.
- 2 The plant-on rafter foot, reducing to match the roofing counter-batten, is a convenient way to deal with composite I beam eaves. It allows the gutter to be placed exactly where it is needed.
- 3 One must sometimes also consider the impact of elements such as purlins and ridge beams on  $\psi$  values; they may constitute further linear non-repeating thermal bridges.

#### Isotherms

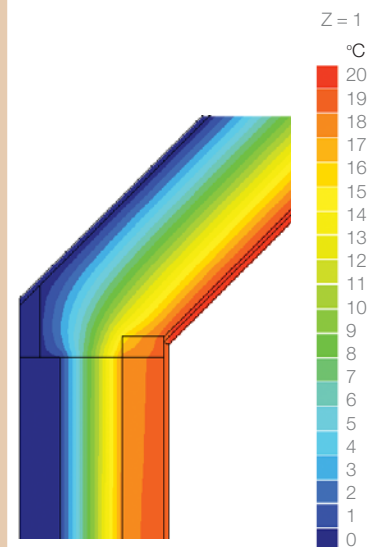

### **Limiting Thermal Bridges**

The main benefit of this design is to improve the wall-roof joint at the eaves, where many modern buildings fail thermally. A modern UK house, with the insulation located on the attic floor, has a reduced thickness of insulation at this point. Using eaves ventilation often allows cold air to get under the insulation - reducing the thermal performance further.

Shown in figure 9 is a detail appropriate to a building with 'rooms in the roof' or other rooms with sloping ceilings. The eaves ventilation is eliminated by the use of carefully chosen components which allow the air space to be outside the low vapour resistance sheathing. This permits the roof and wall insulation to become one continuous layer, giving reduced thermal bridging as shown in figure 9.

The structural consequence of this is that the rafters do not have collars. Rather, they sit on a ridge beam or purlins where a strip of air-vapour barrier has already been folded over before the rafters are placed in situ (to be sealed later to the main roof air-vapour barrier). A simpler option in many cases is if the air barrier is routed below the ridge beam; this results in a small area of flat ceiling below the beam along the ridge line.

### **Airtightness**

Since there is no ventilation within the construction, the risk that unwanted air movement could reduce the performance of the roof insulation is greatly reduced. The roof air-vapour barrier is joined to the masonry wall by using a strip of expanded metal to clamp the membrane to the masonry; this metal lath is subsequently plastered over. If this joint cracks due to movement as the house settles, it is still likely to maintain its airtightness, requiring only a cosmetic repair rather than a difficult sealing job.

Note the use of a sheathing board outside the insulation, providing a firm backing to the low vapour resistance sheathing membrane. This membrane is sealed at seams and helps to block air from penetrating any further into the roof structure, where it could worsen the performance of the thermal insulation.

## Assumptions used in the calculations

The following data was used to determine the basic thermal transmittance of the wall and roof sections:

### SECTION 2

	Element	Thickness (mm)	Thermal Values
<b>WALL</b>  Metal ties 80mm <sup>2</sup> x 2.5/m <sup>2</sup> 17W/mK U=0.248 W/m <sup>2</sup> K  with plastic ties U=0.227 W/m <sup>2</sup> K	R <sub>so</sub>		0.04 Resistance
	Brickwork (outer)	100	0.77 Conductivity
	Mineral wool cavity insulation	150	0.038 Conductivity
	Dense concrete (1800 kg/m <sup>3</sup> )	100	1.30 Conductivity
	Plaster lightweight	13	0.18 Conductivity
	R <sub>si</sub>		0.13 Resistance
<b>ROOF</b>  4% thermal bridging of insulation by I beam web  U=0.141 W/m <sup>2</sup> K	R <sub>so</sub>		0.04 Resistance
	BM OSB	10	0.130 Conductivity
	Blown mineral wool / natural fibre insulation	300	0.040 Conductivity
	OSB VB	10	0.130 Conductivity
	Plasterboard	13	0.21 Conductivity
	R <sub>si</sub>		0.1 Resistance
<b>FLOOR</b>  Assuming Perimeter/area ratio= 0.4  Soil k =1.5 W/m <sup>2</sup> K  U=0.170 W/m <sup>2</sup> K	R <sub>so</sub>		0.04 Resistance
	Expanded polystyrene	150	0.038 Conductivity
	R <sub>si</sub>		0.17 Resistance

1. ANDERSON B Conventions for U-values calculations. BRE report 443 - 2006 version
2. BRE IP 1/06 Assessing the effects of thermal bridges at junctions and around openings 2006
3. BS EN ISO 13789:1999 Thermal Performance of Buildings - Transmission Heat Loss - Calculation Method
4. BS EN ISO 6946 :1997 Building Components and Building Elements - Thermal Resistance and Thermal Transmittance - Calculation Methods
5. BS EN ISO 14683:1999 Thermal Bridges in Building Construction - Linear Thermal transmittance - Simplified methods and default values
6. BS EN ISO 10211 Thermal Bridges in Building Construction - Heat Flows and Surface Temperatures - Part 1 General Calculation Procedures 1995.
7. Ibid. Part 2 Calculation of Linear Thermal Bridges: 1999
8. BS EN ISO 13370:1998 Thermal Performance of Buildings - Heat Transfer via the Ground - Calculation Method
9. Accredited Construction Details - See for instance [http://www.planningportal.gov.uk/uploads/br/masonry\\_cavity\\_wall\\_insulation\\_illustrations.pdf](http://www.planningportal.gov.uk/uploads/br/masonry_cavity_wall_insulation_illustrations.pdf). Caution: this document appears to contain some incorrect advice; e.g. plasterboard-on-dabs is described as an air barrier.
10. KOBRA, KOBRU86, TRISCO - Thermal analysis programs from [www.physibel.be](http://www.physibel.be) 2006-0826
11. Passivhaus Planning Package 2004 / 2007: Specifications for Quality Approved Passive Houses. Passivhaus Institut, Darmstadt, Germany.
12. SAP-2005. Appendix K, Thermal Bridging. Downloadable from [bre.co.uk/sap2005](http://bre.co.uk/sap2005).



These constructional examples are used to show how key design principles can be applied to common details. The U-value and  $\psi$ -value of each constructional example are given and there is a commentary on how thermal bridging is reduced and airtightness is improved.

### 3.1: Platform frame (room in roof format) - basic principles

The basic principles for achieving highly-insulated and airtight timber construction are discussed and the requirements for reducing thermal bridges and reducing the risk of interstitial condensation are covered.

The three details illustrated in this document show how timber-frame construction can be designed to:

- Be highly-insulated and airtight;
- Have reduced thermal bridging; and
- Minimise the risk of interstitial condensation.

This can be achieved by following three simple rules.

1. Make the insulation continuous so that the insulation in one element connects seamlessly to the insulation in the next element. This reduces or almost eliminates the linear thermal bridges.
2. Ensure that the insulation is contained within airtight layers, ideally to both sides. This will ensure that cold outside air does not find its way to the warm side of the insulation.
3. Provide the construction with a designated air barrier, a material that blocks air movement; and if necessary a vapour barrier, to control vapour diffusion. In a timber-frame structure, the air barrier may often be a polyethylene membrane.

### 3.1.1: The basic construction – wall

## SECTION 3

FIGURE 10

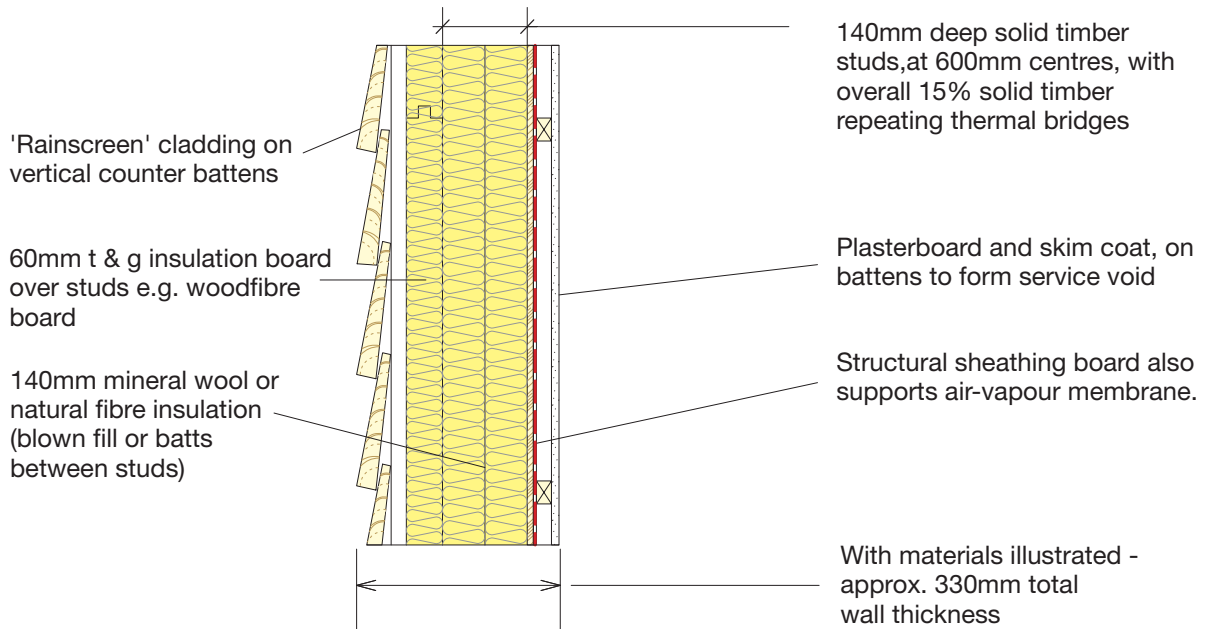

#### U-values (UK approach)

##### Basic wall construction

Assuming the standard UK convention for repeating thermal bridges of 15%: **U = 0.23 W/m<sup>2</sup>K**

#### ψ values for linear thermal bridges

	ψ int W/mK	ψ ext W/mK
<b>As shown</b>		
<b>Wall/wall junctions</b>		
<b>Vertical values</b>		
<b>Internal corner</b>	<b>-0.07</b>	<b>0.00</b>
<i>Compare UK Accredited Constructions</i>	<i>0.09</i>	
<b>External corner</b>	<b>0.05</b>	<b>0.00</b>
<i>Compare UK Accredited Constructions</i>	<i>0.09</i>	
<b>Party wall</b>	<b>0.08</b>	<b>0.00</b>
<i>Compare UK Accredited Constructions</i>	<i>0.06</i>	

#### Notes

1. Timber-frame wall using: mineral wool or cellulose fibre between 38 x 140 mm studs; 60 mm woodfibre tongue and groove sheathing board fixed over studs; ventilated timber clad rainscreen.
2. This is the basic wall construction assumed throughout this document.
3. A similar but thinner wall, using the cheaper 89 mm frame, and overlaid with up to 50 mm of polyurethane foam insulation (instead of woodfibre board), is widely used in the USA. This construction can give a similar U-value to the wall which we analyse here.

### **Reduced Thermal Bridging**

The major thermal bridges associated with timber-frame construction are in the solid timber itself. There has been much UK discussion of what fraction of the wall is made up of solid timber rather than insulation. The UK uses 15% timber as a default to cover the repeating thermal bridges. Designers are supposed to make a further allowance to cover the non-repeating thermal bridges. It is not known to what extent they do.

Timber fractions up to 35%, i.e. including all thermal bridges, were reported by researchers who examined standard timber-frame houses erected in the UK. Work in the USA has shown that this can be reduced by more care in design. The U-value of a timber-frame wall is clearly extremely sensitive to the overall timber fraction.

This construction keeps a 140 mm frame and overlads it with continuous insulation sheathing. This reduces, although it does not eliminate, the effect of the thermal bridges within the timber frame.

The quoted U-value of 0.23 is based on a timber fraction of 15%. Designers and builders must take care to ensure that the timber fraction is no more than 15% or take into account any likely increased timber fraction when calculating the U - value of the wall construction for a particular site-built project or off-site prefabricated product.

### **Airtightness**

The basic airtightness of the wall is maintained by the air - vapour barrier membrane, which is fixed over the internal face of the OSB, with joints lapped, sealed with a suitable material and clamped. One way of clamping the joint would be to use the battens forming the service cavity for this purpose. Basic services can be run in the service void behind the plasterboard and pictures, shelves, etc can be hung on the wall without damaging the airtightness. Also the plasterboard finish can crack without affecting the airtightness of the structure.

### 3.1.1: The basic construction – floor

## SECTION 3

FIGURE 11

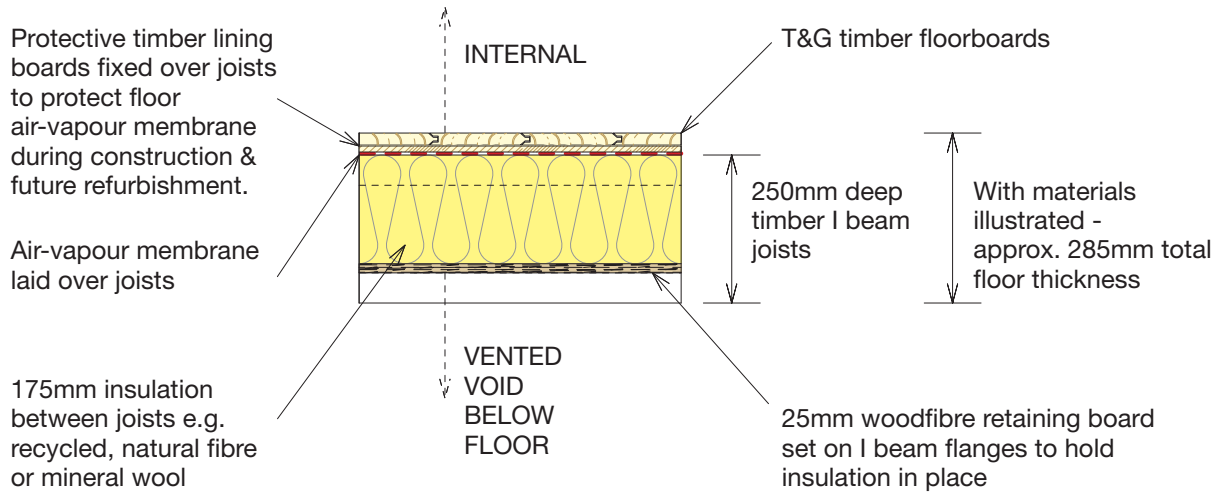

#### U-values (UK approach)

##### Basic floor construction

$$U = 0.16 \text{ W/m}^2\text{K}$$

(excluding floor finish)

#### Notes

1. The floor insulation thickness needed depends on the size of the slab. The U-value will be poorer for; e.g., a small detached house.
2. Careful consideration needs to be given to the remaining depth in the 'I' joist after the retaining board is placed on the lower 'I' beam flange. The remaining depth should be fully filled to ensure there is no chance for air circulation on the underside of the floor's air-vapour barrier/protective timber lining. Standard manufacturers' depths / application methods for the specific insulation product specified should be borne in mind when dimensioning this detail.

### 3.1.1: The basic construction – roof

## SECTION 3

FIGURE 12

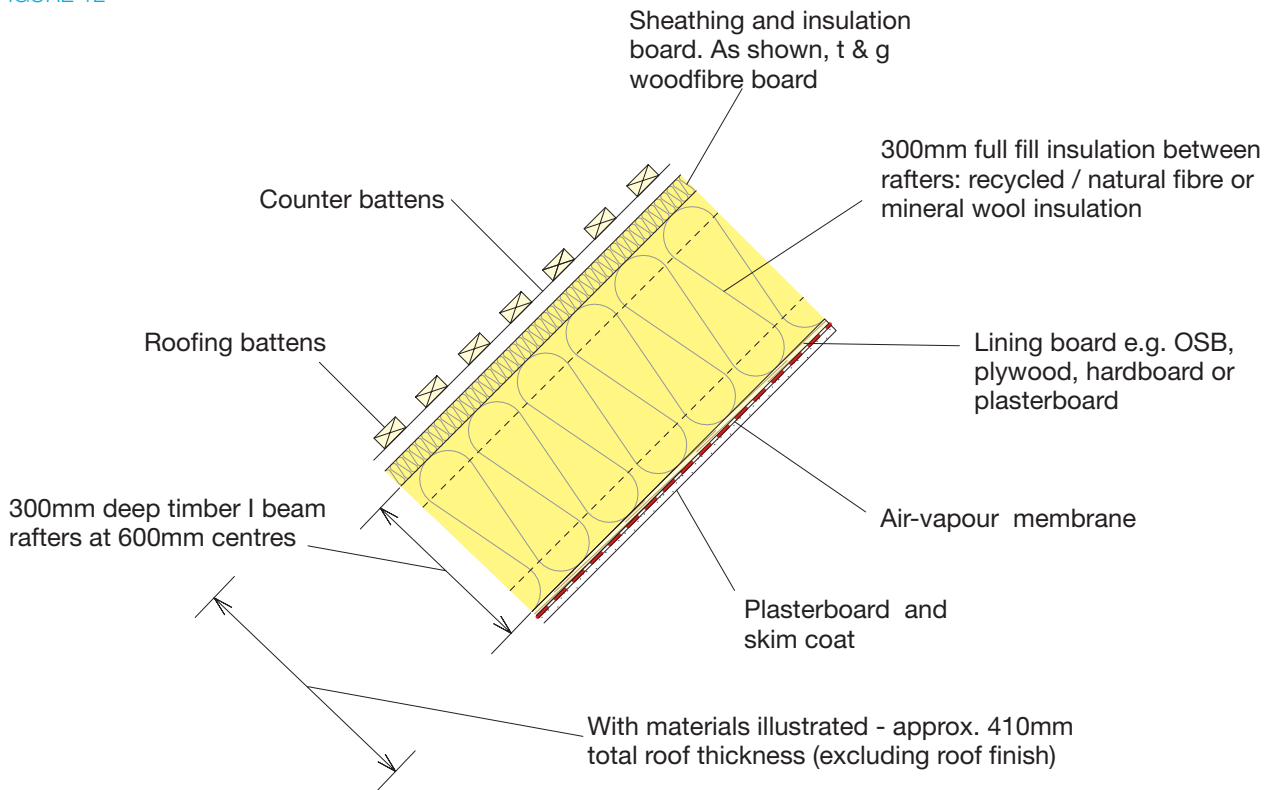

#### U-values (UK approach)

##### Basic roof construction

$$U = 0.14 \text{ W/m}^2\text{K}$$

(4% web bridging, 15% flange bridging, allowance for noggings)

### 3.1.2: Roof to wall junction

## SECTION 3

FIGURE 13

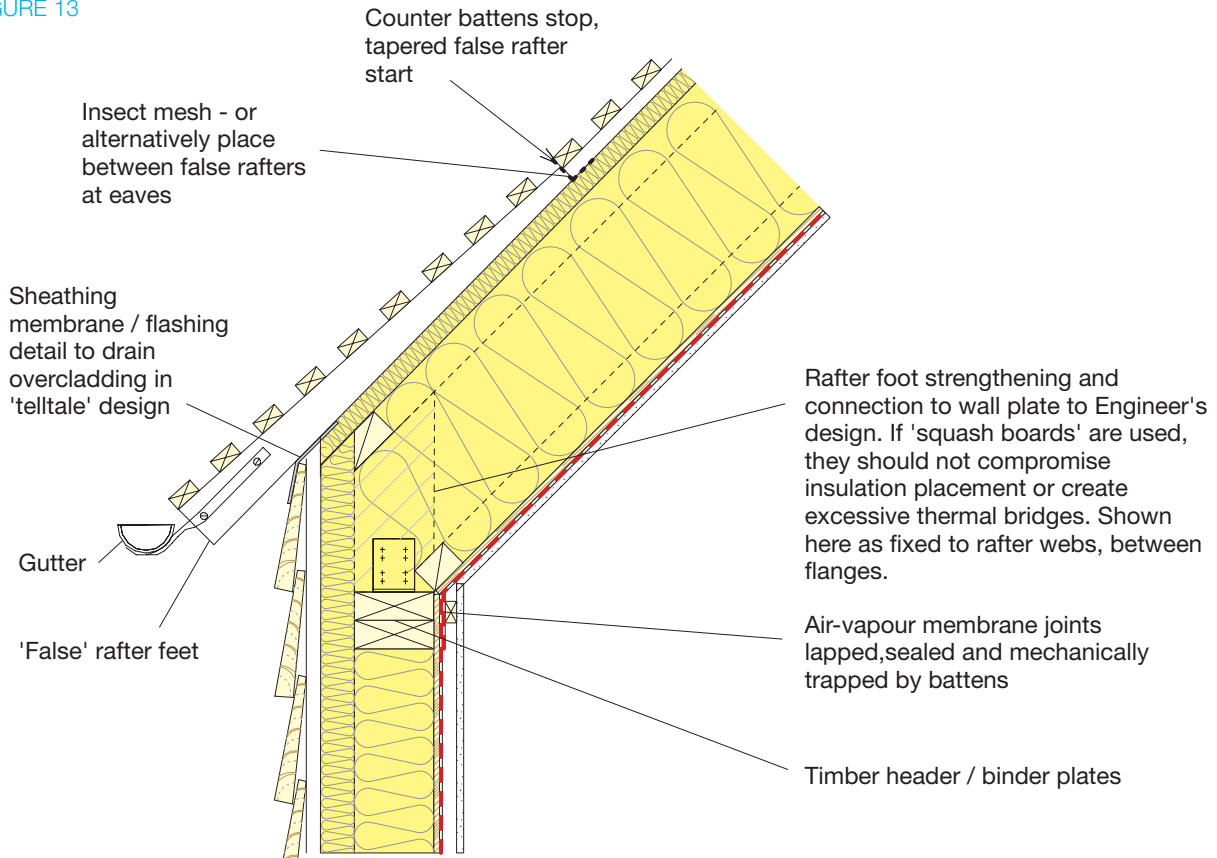

#### ψ values for linear thermal bridges

	ψ int W/mK	ψ ext W/mK
<b>As shown</b>		
At eaves	0.04	0.06
Compare UK Accredited Constructions	0.03	
<b>Variations</b>		
With single timber at wall plate level	0.03	-0.07
At verge, assuming continuous insulation between cavity and roof - y	0.03	-0.07

#### Notes

1. The plant-on rafter foot, reducing to match the roofing counter-batten is a convenient way to deal with composite I beam eaves, allowing the gutter to be placed exactly where it is needed.
2. This is based on using mineral wool insulation with  $\lambda = 0.042$  W/mK. The U-value can be improved by using insulation with a lower  $\lambda$ -value.

#### Isotherms

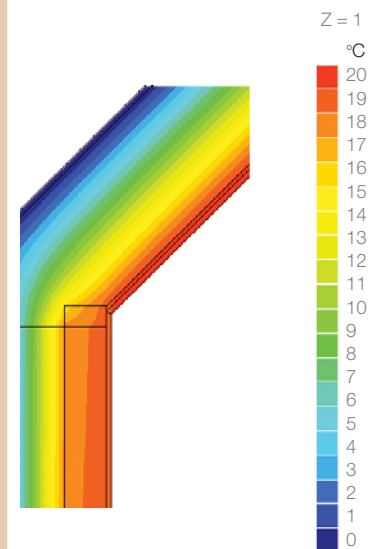

### **Reduced Thermal Bridging**

The main point which this design addresses is to eliminate the need to introduce ventilation of the insulation at the eaves, a point where many modern buildings fail to keep the heat in. The ventilation at eaves has been eliminated by the use of carefully chosen components which make the structure vapour-permeable on the outside, permitting the roof and wall insulation to become continuous.

Polyethylene is often used for this membrane and is carried down to meet the membrane in the wall. The membrane needs to be sealed at this junction.

### **Airtightness**

The absence of ventilation provision within the construction has been mentioned above. The air barrier throughout the structure is a high vapour resistance membrane, which is sealed at seams.

Note the use of a sheathing board for the final roof covering under the tiles. This provides a firm backing to the low vapour resistance membrane. This layer is sealed at seams and acts as a barrier to wind penetration into the roof structure, which could worsen the performance of the thermal insulation.

### 3.1.3: Wall to suspended ground floor junction

## SECTION 3

FIGURE 14

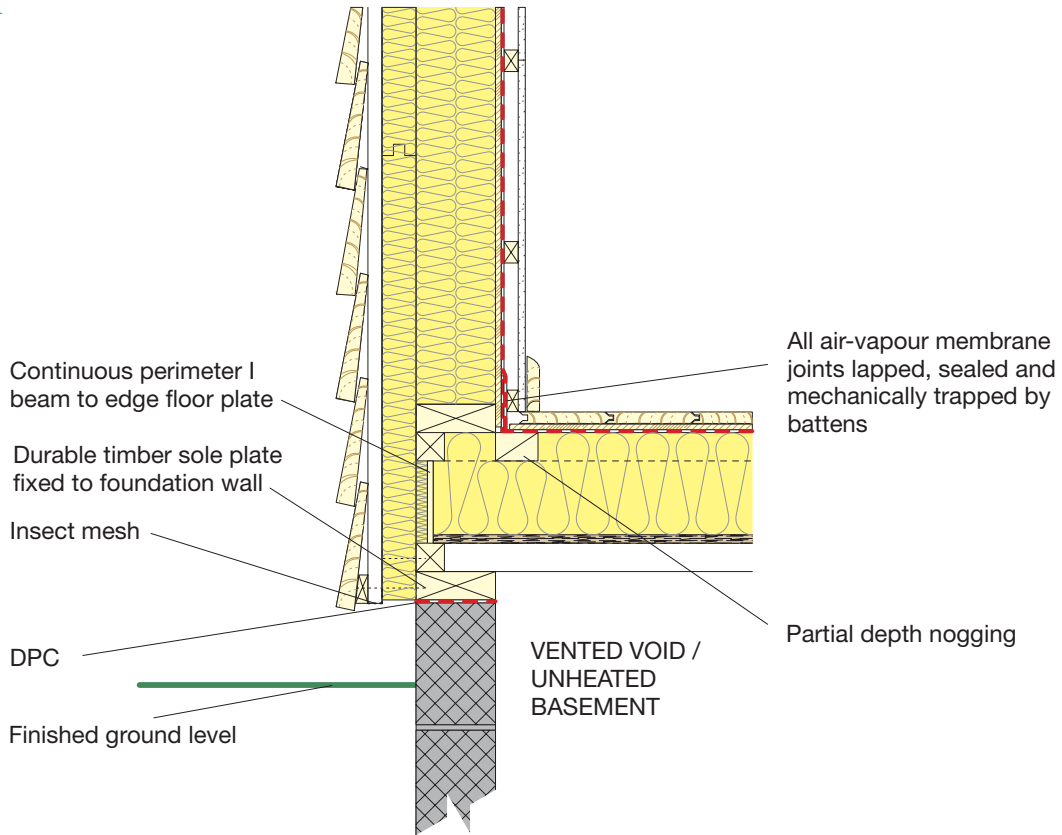

#### ψ values for linear thermal bridges

	ψ <sub>int</sub> W/mK	ψ <sub>ext</sub> W/mK
<b>As shown</b>	<b>0.09</b>	<b>0.00</b>
<i>Compare UK Accredited Constructions</i>	0.16	

#### Notes

- 1 These psi values exclude the impact of any other thermal bridges within the ground floor construction; e.g., glulam or steel beams used to increase the span.

#### Isotherms

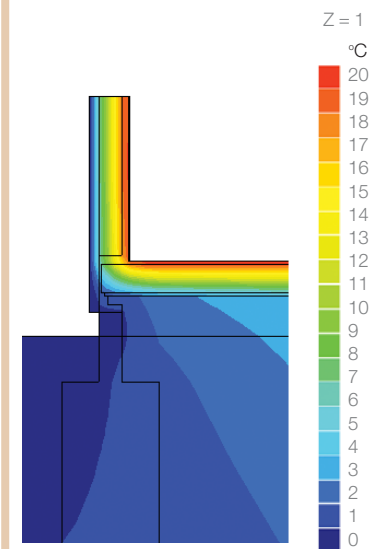



### **Reduced Thermal Bridging**

In this case, the main method used is to keep the floor insulation zone as contiguous as possible with the wall insulation. Note the noggin under the inside of the floor, which is used in preference to a doubling-up of the edge beam. The resulting isotherms are shown on the previous page.

### **Airtightness**

The membrane on the inside of the wall is continuous with the floor membrane and the two must be overlapped, sealed and clamped at seams. Pipes, wiring and ducts from below must be run in ducts which are sealed to the fibreboard and the airtightness membrane, using non-hardening compounds.

### 3.1.4: Timber-Frame Wall and Intermediate Timber Floor Junction, Parallel to Joists

#### SECTION 3

FIGURE 15

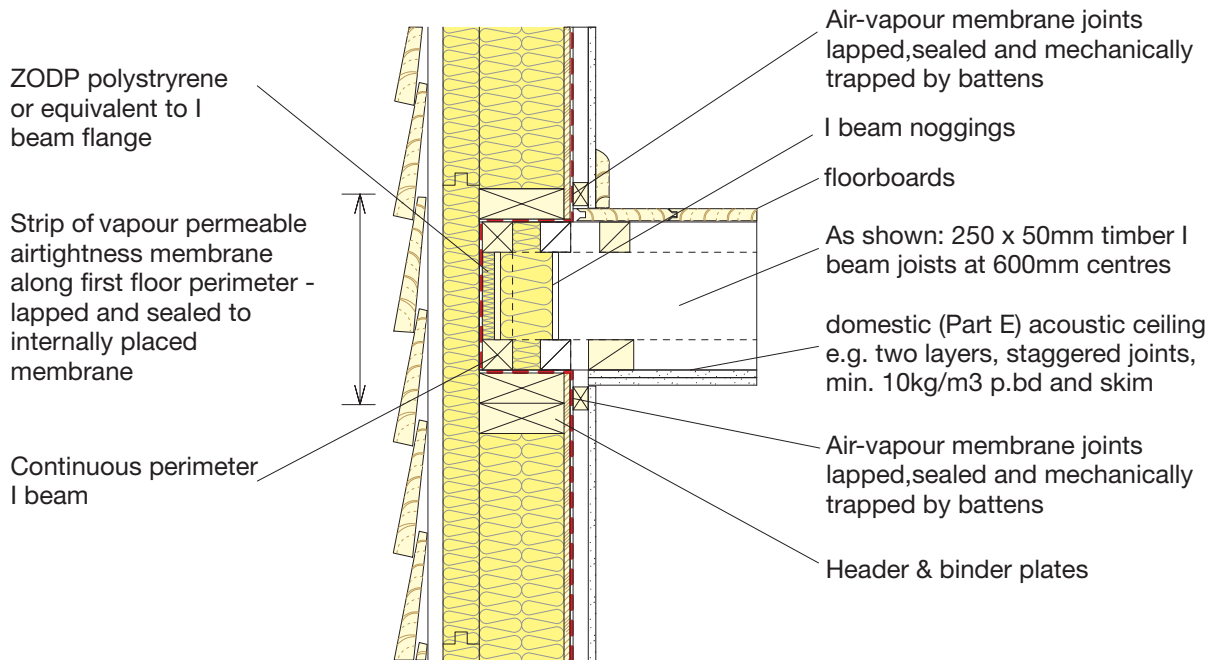

#### ψ values for linear thermal bridges

	ψ int W/mK	ψ ext W/mK
<b>As shown</b>		
Intermediate floor	0.03	0.03
Compare UK Accredited Constructions	0.07	

#### Notes

It is assumed that the binder plate is necessary to bring the top of the wall panels into line before the first floor is placed in position

#### Isotherms

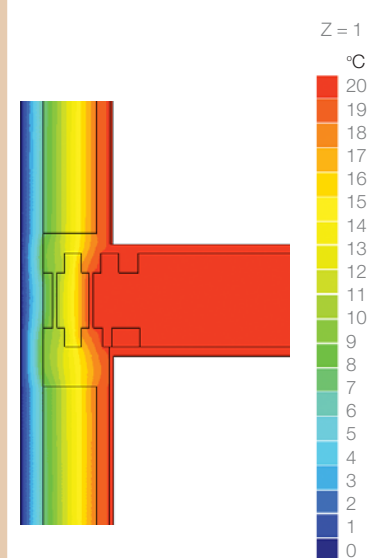

### **Reduced Thermal Bridging**

Here the main method used to reduce thermal bridging is to insulate the walls in the intermediate floor zone. This should be done before the second floor wall panels are lifted, in conjunction with the air barrier described below. The result is greatly reduced thermal bridging; see isotherms in figure 6.

### **Airtightness**

To construct this detail with low air leakage requires care and planning: After the ground floor wall is assembled and clamped with the binder plate, a strip of heavy-duty breather membrane has to be draped over the wall and the floor joists assembled on top of it. Once the floor is stable, the breather membrane is folded around and over the top of the floor, ready to lap onto the air-vapour barrier in the main second floor wall panels - and the air-vapour barrier in the ground floor walls. Alternatively the air-vapour barrier could be placed over the wall before the binder plate. This has a potential benefit of protecting the membrane when the floor panels are lowered into place.

To avoid an interstitial condensation risk, a breather membrane must be used where the air barrier wraps around the outside of the first floor. But even heavy-duty versions of breather membranes are less airtight than polyethylene, so its use as the air-vapour barrier elsewhere in the building is not recommended.

## Assumptions used for calculations

### SECTION 3

	Element	Thickness (mm)	Thermal Values
<b>WALL</b>  15% repeating thermal bridges (standard UK convention)  $U=0.229 \text{ W/m}^2\text{K}$	RSO		0.13 Resistance
	Woodfibre board	60	0.050 Conductivity
	Blown mineral wool / natural fibre insulation	140	0.040 Conductivity
	Studs		0.130
	OSB	11	10.140 Conductivity
	VC		
	Cavity	25	0.180 Resistance
	Plasterboard	13	0.21 Conductivity
	RSI		0.13 Resistance

	Element	Thickness (mm)	Thermal Values
<b>ROOF</b>  4% thermal bridging of insulation by I beam web  15% by I beam flanges both $k = 0.13 \text{ W/mK}$  $U=0.135 \text{ W/m}^2\text{K}$	RSO	roof	0.04 Resistance
	Woodfibre board based on sarket	20	0.050 Conductivity
	Blown mineral wool / natural fibre insulation	300	0.040 Conductivity
	OSB	10	0.130 Conductivity
	VC		
	Plasterboard	13	0.210 Conductivity
	RSI		0.1 Resistance

	Element	Thickness (mm)	Thermal Values
<b>FLOOR</b>  Assuming perimeter/area ratio= 0.4  Soil $k = 1.5 \text{ W/m}^2\text{K}$  Standard ventilation, $U = 0.160 \text{ W/m}^2\text{K}$ - excluding floor finish.  4% bridging from web, 15% bridging from flange	RSO		0.17 Resistance
	Woodfibre board	25	0.050 Conductivity
	Blown mineral wool / natural fibre insulation	175	0.040 Conductivity
	Timber protection layer	11	0.130 Conductivity
	RSI		0.17 Resistance

## References

### SECTION 3

1. ANDERSON B Conventions for U-values calculations. BRE report 443 - 2006 version
2. BRE IP 1/06 Assessing the effects of thermal bridges at junctions and around openings 2006
3. BS EN ISO 13789:1999 Thermal Performance of Buildings - Transmission Heat Loss - Calculation Method
4. BS EN ISO 6946 :1997 Building Components and Building Elements - Thermal Resistance and Thermal Transmittance - Calculation Methods
5. BS EN ISO 14683:1999 Thermal Bridges in Building Construction - Linear Thermal transmittance - Simplified methods and default values
6. BS EN ISO 10211 Thermal Bridges in Building Construction - Heat Flows and Surface Temperatures - Part 1 General Calculation Procedures 1995.
7. Ibid. Part 2 Calculation of Linear Thermal Bridges: 1999
8. BS EN ISO 13370:1998 Thermal Performance of Buildings - Heat Transfer via the Ground - Calculation Method
9. Accredited Construction details - from [www.planningportal.gov.uk](http://www.planningportal.gov.uk); see for instance [http://www.planningportal.gov.uk/uploads/br/wood\\_frame\\_illustrations.pdf](http://www.planningportal.gov.uk/uploads/br/wood_frame_illustrations.pdf).
10. KOBRA, KOBRU86, TRISCO - Thermal analysis programs from [www.physibel.be](http://www.physibel.be) 2006-0826
11. Passivhaus Planning Package 2004 / 2007: Specifications for Quality Approved Passive Houses. Passivhaus Institut, Darmstadt, Germany.
12. SAP-2005. Appendix K, Thermal Bridging. Downloadable from [bre.co.uk/sap2005](http://bre.co.uk/sap2005).
13. [http://65.175.72.244/design/building\\_science/internal\\_barriers/a\\_standards.php](http://65.175.72.244/design/building_science/internal_barriers/a_standards.php). Canadian government information on the air permeability of some common building materials, especially those used in timber-frame construction.